

Nexus Audio Systems

C-612 MULTI-ROOM CONTROLLER

RS232 Command Reference



RS232 PROTOCOL

The C-612 Controller has an RS-232 port that allows the system to be controlled with an external controller or become a sub-system in a whole-house control package. This allows the system installer to integrate the operations of the C-612 with other control systems in the home.

The C-612 Serial Port allows full control of all system functions. In addition to being able to control the C-6/expansion Controllers 'on board' functions (on/off, input select, etc) RS-232 control includes control of the Tuner and other source components, including any attached iPod/dock combinations. When the C-612 'sees' a command for one of the on board functions, it responds accordingly. When it sees a command such as CD play, the incoming RS-232 command is interpreted in a similar manner to a keypad button press and the C-612 will output the appropriate corresponding IR command.

The Serial Port on the C-6 uses a female DB9 connector wired in a DTE configuration. Tx (transmit) = pin 2, Rx (receive) = pin 3, Ground = pin 5. Communication settings are 19200 baud, 8 bits, no parity, no handshake.

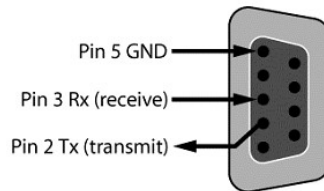

Figure 1. RS-232 Port Pin Out

Each command must be terminated with a carriage return: <cr>. If an invalid command is sent, the C-612 will respond with ERR. If a valid command is sent, the C-612 will respond with OK unless it is a query type command, in which case the C-612 will respond with information. Every response from the C-612 is terminated with <cr>.

The C-612 sends out unsolicited information whenever a keypad is operated. The syntax is the same as that used for controlling the C-612. For instance, if someone turns on Zone 1 via a keypad, the C-612 will transmit Z011 out of the serial port. The string will be terminated with <cr>.

Note: the symbol <cr> shown in the table below represents a carriage return control character whose value is hex 0x0d. This is what must be transmitted to the C-612 at the end of every command, not the characters <, c, r, >.

RS232 command table starts on next page.

Command	Syntax	Parameters	Description
Zone Power	Zxxy<cr>	xx=zone, valid range 01-12 y=state, 1=on, 0=off	Similar to pushing the power button on a zones keypad. This will power up/down the specified zone
Zone Power Query	Zxx?<cr>	xx=zone, valid range 01-12	Ask the C-612 if a zone is on or off. The C-612 will respond with Zxx1 for zone on, and Zxx0 for zone off. xx is the zone number queried.
All off	ZA0<cr>	0=off	Turn all zones off. If an Expansion Controller is connected, it's zones will also be turned off.
All on	ZA1<cr>	1=0n	Turn all zones on. They will be set to their last used source and volume.
Source Select	Sxxy<cr>	xx=zone, valid range 01-12 y=input, range T, 1-6	Similar to selecting a source on a keypad. T=tuner, 1-6=inputs 1-6. Inputs 5 and 6 correspond to expansion slots 1 and 2.
Source Query	Sxx?<cr>	xx=zone, valid range 01-12	Ask the C-612 what input a zone is on. The C-612 will respond with Sxxy, where xx is the zone number queried and y the input it is set to.
Function	Fxxy<cr>	xx=zone, valid range 01-12 yy=function: on keypad: SU, SD, RW, FW, ST, PS. Additional on IR remote: GU, IN, EX, MN, CU, CD, NU, NR, ND, NL, EN, N1, N2, N3, N4, N5, N6, N7, N8, N9, N0, TR, DI.	Similar to pressing a function on a keypad or remote. SU=scroll up, SD=scroll down, RW=rewind, FF=fast forward, ST=star, PS=pause. R-3 Remote only: GU=guide, IN=info, EX=exit, MN=menu, CU=ch up, CD=ch down, NU=nav up, NR=nav right, ND=nav down, NL=nav left, EN=enter, N1-N0=numeric buttons, TR=track, DI=disc.
Volume Absolute	Vxxyy<cr>	xx=zone, valid range 01-12 yy= volume, range 00-99	Set an absolute volume level in a C-612 zone. NOTE: yy number is in dB so 00 is the loudest at 0dB and 99 is the softest at -99dB.
Volume Query	Vxx?<cr>	xx=zone, valid range 01-12	Ask the C-612 what volume a zone is set to. The C-612 will respond with Vxxyy where xx is the zone number, (01-12) and yy is the volume of that zone (00-99) = 0dB to -99dB

Volume Step	Vxx++<cr> or Vxx- -<cr>	xx=zone, valid range 01-12	Increase or decrease the volume of a zone by one step (1dB).
Command	Syntax	Parameters	Description
Frequency Query	FREQ?<cr>	none	Query what frequency the Tuner is on. The reply will be 'FM' or 'AM' followed by the frequency. Example: 'FM105.9' or 'AM1010'
FM tuner frequency	FMFxxxx<cr>	xxxx=frequency, valid range 0875-1079, leading zeros required.	Set the FM frequency of the C-612 internal tuner. If the tuner is on the AM band, it will switch to FM.
AM tuner frequency	AMFxxxx<cr>	xxxx=frequency, valid range 0530-1710, leading zeros required.	Set the AM frequency of the C-612 internal tuner. If the tuner is on the FM band, it will switch to AM.
Switch to FM	FMB<cr>	none	Switch to the FM band without changing the frequency.
Switch to AM	AMB<cr>	none	Switch to the AM band without changing the frequency.
Frequency Seek	SEEKx<cr>	x = + or x = -	Seek up or down the current band (FM or AM), and stop on the next station.
Mute on	MUTE_ONxx<cr>	xx=zone, valid range 01-12	Activates mute on the desired zone xx. If xx is omitted, then zones will mute according to those enabled in the mute menu.
Mute off	MUTE_OFFxx<cr>	xx=zone, valid range 01-12	De-activates mute on the desired zone xx. If xx is omitted, then zones will unmute according to those enabled in the mute menu.
Treble	Txxyy	xx=zone, valid range 01-12 yy= value, range 00-20	Adjusts the treble for a given zone. The adjustment range is -10dB to +10db with 0dB being flat, so a yy value of 0 = -10dB, 10 = 0dB, 20 = +10dB.
Bass	Bxxyy	xx=zone, valid range 01-12 yy= value, range 00-20	Adjusts the bass for a given zone. The adjustment range is -10dB to +10db with 0dB being flat, so a yy value of 0 = -10dB, 10 = 0dB, 20 = +10dB.

Nexus C-612 iPod control protocol

This section describes the commands used to control an iPod attached to a Nexus C-612 via the RS232 port on the rear of the unit. The RS232 port uses a baud rate of 19200, 8 data bits, 1 stop bit, and no parity. In the examples shown, the string <cr> represents a carriage return; a single byte non-printable character with the hexadecimal value 0x0d. For information regarding connecting an iPod dock to the C-612, please refer to the Nexus C-612 installation guide.

Command list.

I_SLOT1

This command allows a device attached to the RS232 port to take control of an iPod attached to slot 1 of the C-612. If the iPod is not in use, a reply of “OK” will be returned. If the iPod is in use (by a keypad), a reply of “ERR iPod in use” will be returned. After this command is issued, and if successful, a 32 second timer will be started. If any iPod related commands are sent to the controller, this timer will be reset. If no iPod related commands are received for 32 seconds, a reply of “Slot1 timeout” will be returned, and the RS232 port loses control of the iPod.

Example:

```
--> I_SLOT1<cr>  
<-- OK<cr>
```

I_SLOT2

Same as I_SLOT1, but instead takes control of an iPod on slot 2.

I_RELIPOD

When the device on the RS232 is finished controlling the iPod, it should issue this command to make the iPod available to the system.

Example:

```
--> I_RELIPOD<cr>  
<-- OK<cr>
```

I_RESDBSEL

Resets the iPod's database selection to an empty state, and sets the category count to zero. This is analogous to pressing the iPod menu button repeatedly to get to the topmost iPod menu. Any previously selected database items are de-selected. The command has no effect on the playback engine – any songs currently in the play queue will continue to play.

Example:

```
--> I_RESDBSEL<cr>  
<-- OK<cr>
```

I_GETNUMCATDBREC

Retrieves the number of records in a particular database category. For example, the number of artists, or albums in the iPod database could be queried. The category types available are as follows:

Playlist = 01

Artist = 02
Album = 03
Genre = 04
Track = 05
Composer = 06
AudioBook = 07
Podcast = 08

This command must be used to initialize the category count before selecting a database record using the I_SELDBRECORD command. A categories record count can change based on prior categories selected and the database hierarchy. For example, if the database has just been reset using I_RESDBSEL, then this command would return the total number of records for a given category. However, if this command is sent after one or more categories have been selected, the returned record count will be a subset of the records that are member of all the categories selected prior to this command.

Example:

```
--> I_GETNUMCATDBREC 02<cr>      'request the number of artists
<-- 184<cr>                       'there are 184 artists
```

I_RETCATDBREC

Retrieves one or more database records from the iPod based on the results from the I_GETNUMCATDBREC command. This command specifies the category type (see above), the starting record index, and the record count. For example, using a category type of two (artist), a starting index of zero, and a record count of five, the iPod will return the names of the first five artists in the database.

Example:

```
--> I_RETCATDBREC 02,0,5<cr>  'request artist names starting at record 0, get 5 artists
<-- a-ha<cr>                    '5 artist names are returned
<-- Aaron Neville<cr>
<-- AC/DC<cr>
<-- Adam Ant<cr>
<-- Aerosmith<cr>
```

I_SELDBREC

Selects one or more records in the iPod database, based on a category relative index. For example selecting category two (artist), and record index one results in a list of database records from the second artist in the artist list. Selections are additive and limited by the category hierarchy. Selection of a single record automatically passes it to the playback engine and starts its playback. This command may only be used after a category count has been initialized by use of the command I_GETNUMCATDBREC.

Example:

```
--> I_SELDBREC 02,2<cr>      '(see above) Artist number 2 (AC/DC) is selected
<-- OK<CR>
```

I_PLYCURSEL

This command copies items from the iPod's database engine to the playbacks engine, and optionally shuffles the tracks if shuffle is active, then starts playback at the specified track index.

Example:

```
--> I_PLYCURSEL 0<cr>  
<-- OK<CR>
```

I_GETPLYSTAT

Requests the current iPod playback status. A reply of “Playing”, “Paused”, or “Stopped” will be returned.

Example:

```
--> I_GETPLYSTAT<cr>  
<-- Playing<CR>
```

I_GETCURPLYTRIND

Requests the index of the currently playing track in the playback engine. The index is returned.

Example:

```
--> I_GETCURPLYTRIND<cr>  
<-- 12<CR>
```

I_GETINDPLYTRTIT

Requests the currently playing track title. The track title will be returned.

Example:

```
--> I_GETINDPLYTRTIT 12<cr>  
<-- Track1: Walking On Broken Glass<CR>
```

I_GETINDPLYTRART

Requests the currently play track artist. The artist name will be returned.

Example:

```
--> I_GETINDPLYTRART 12<cr>  
<-- Artist1: Annie Lennox<CR>
```

I_GETINDPLYTRALB

Requests the currently playing track album name. The album name will be returned.

Example:

```
--> I_GETINDPLYTRALB 12<cr>  
<-- Album1: Medusa<CR>
```

I_PLYCONT

Controls the playback state of the iPod. If the iPod is already in the requested state, then this command has no effect. The states that the iPod can be put into are listed below:

Toggle play/pause = 01

Stop = 02

Next track = 03

Previous track = 04

Start FF = 05
Start REW = 06
End FF/REW = 07
Next = 08
Previous = 09
Play = 10
Pause = 11

Note: if the current track is an audiobook or podcast, then Next and Previous commands skip to the next or previous chapter. Otherwise, they act like Next track and Previous track.

Example:

```
--> I_PLYCONT 01<cr>           'Toggle Play/Pause
<-- ÖK<CR>
```

I_GETSHUF

Requests the current shuffle status of the iPod. The reply will be Shuffle off, Shuffle tracks, Shuffle albums.

Example:

```
--> I_GETSHUF<cr>
<-- Shuffle off<CR>
```

I_SETSHUF

Sets the shuffle state of the iPod. Use 00 to turn shuffle off, 01 to shuffle tracks, or 02 to shuffle albums.

Example:

```
--> I_SETSHUF 01<cr>           'Shuffle albums
<-- ÖK<CR>
```

I_GETREP

Requests the current repeat status of the iPod. The reply will be Repeat off, Repeat 1, or Repeat all.

Example:

```
--> I_GETREP<cr>
<-- Repeat off<CR>
```

I_SETREP

Sets the repeat state of the iPod. Use 00 to turn repeat off, 01 to repeat one track, or 02 to repeat all tracks.

Example:

```
--> I_SETREP 01<cr>           'Repeat 1 track
<-- ÖK<CR>
```

I_GETNUMPLYTR

Requests the number of tracks in the list of tracks queued to play on the iPod.

Example:

```
--> I_GETNUMPLYTR<cr>  
<-- 14<CR>
```

I_SETCURPLYTR

Sets the index of the track to play in the now playing playlist on the iPod. The number of playing tracks, and the current playing track index may be queried using I_GETNUMPLYTR and I_GETCURPLYTRIND. This command only works if the iPod is in the play or pause modes, not in the stop mode.

Example:

```
--> I_SETCURPLYTR 7<cr>  
<-- OK<CR>
```

I_REQIPODNAM

Requests the name of the attached iPod. The name will be returned. If the user has not set a name for the iPod, then “iPod” will be returned.

Example:

```
--> I_REQIPODNAM<cr>  
<-- John's iPod<CR>
```

I_METADATAAON

This command enables reporting of the artist, album, and track names out of the RS232 port. This info will be reported every time the track changes without having to request it. Each item is reported with a field identifier, and a carriage return at the end. For example, if the song changes on the iPod which is on slot 1, the following will be sent out the serial port:

```
Artist1: Beck  
Album1: Sea Change  
Track1: The Golden Age
```

For the iPod on slot 2, the prefixes will be Artist2: Album2: and Track2

Example:

```
--> I_METADATAAON<cr>  
<-- OK<CR>
```

I_METADATAOFF

Cancels reporting of song metadata out of the serial port. This information could still be requested manually using the commands I_GETCURPLYTRIND, I_GETINDPLYTRTIT, I_GETINDPLYTRART, and I_GETINDPLYTRALB.

Example:

```
--> I_METADATAOFF<cr>  
<-- OK<CR>
```

Examples: The following example shows a conversation that might occur if the interfacing device is capable of displaying a maximum of five menu items at a time, and the iPod has a database of eight Artists.

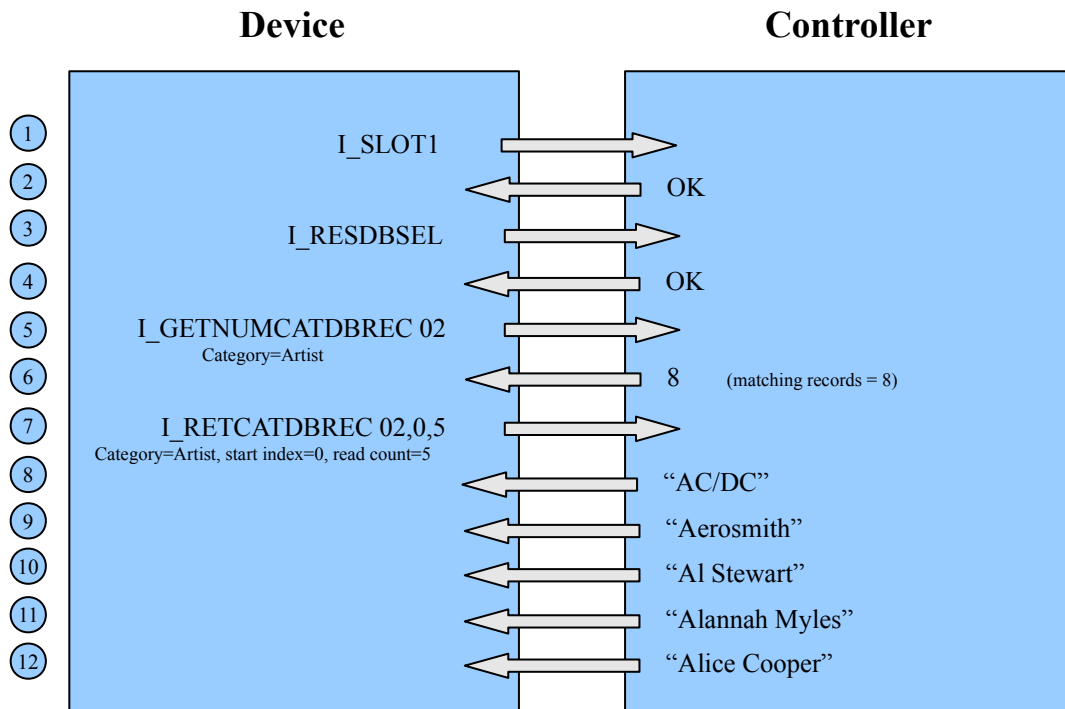

User chooses next page of the Artist list...

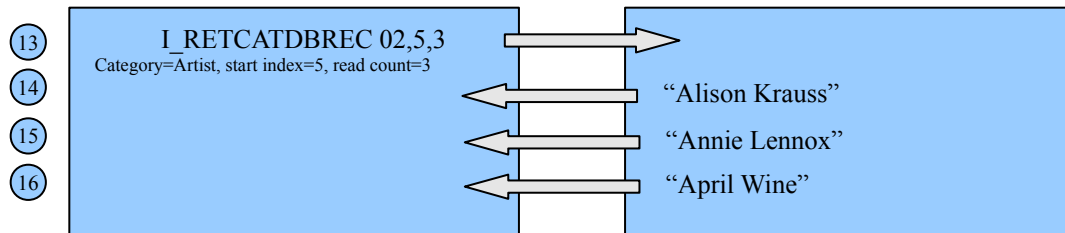

User selects Annie Lennox...

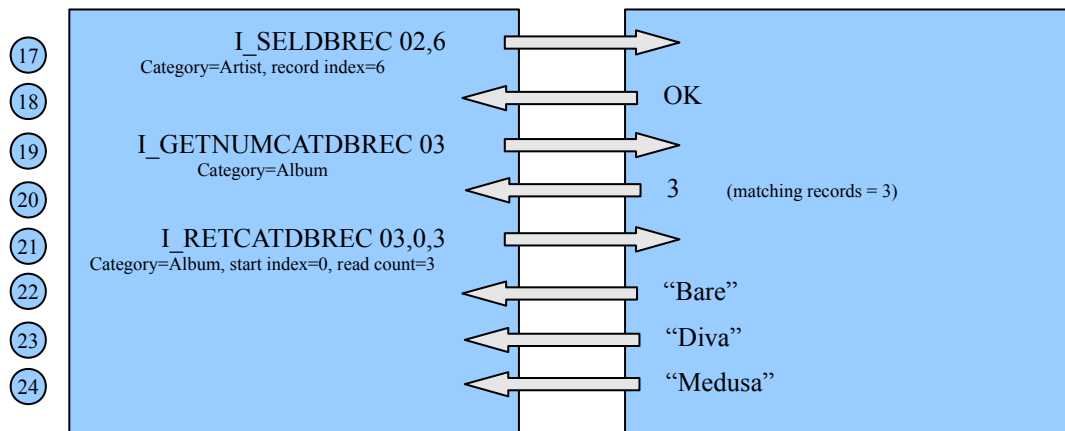

Example: Continued

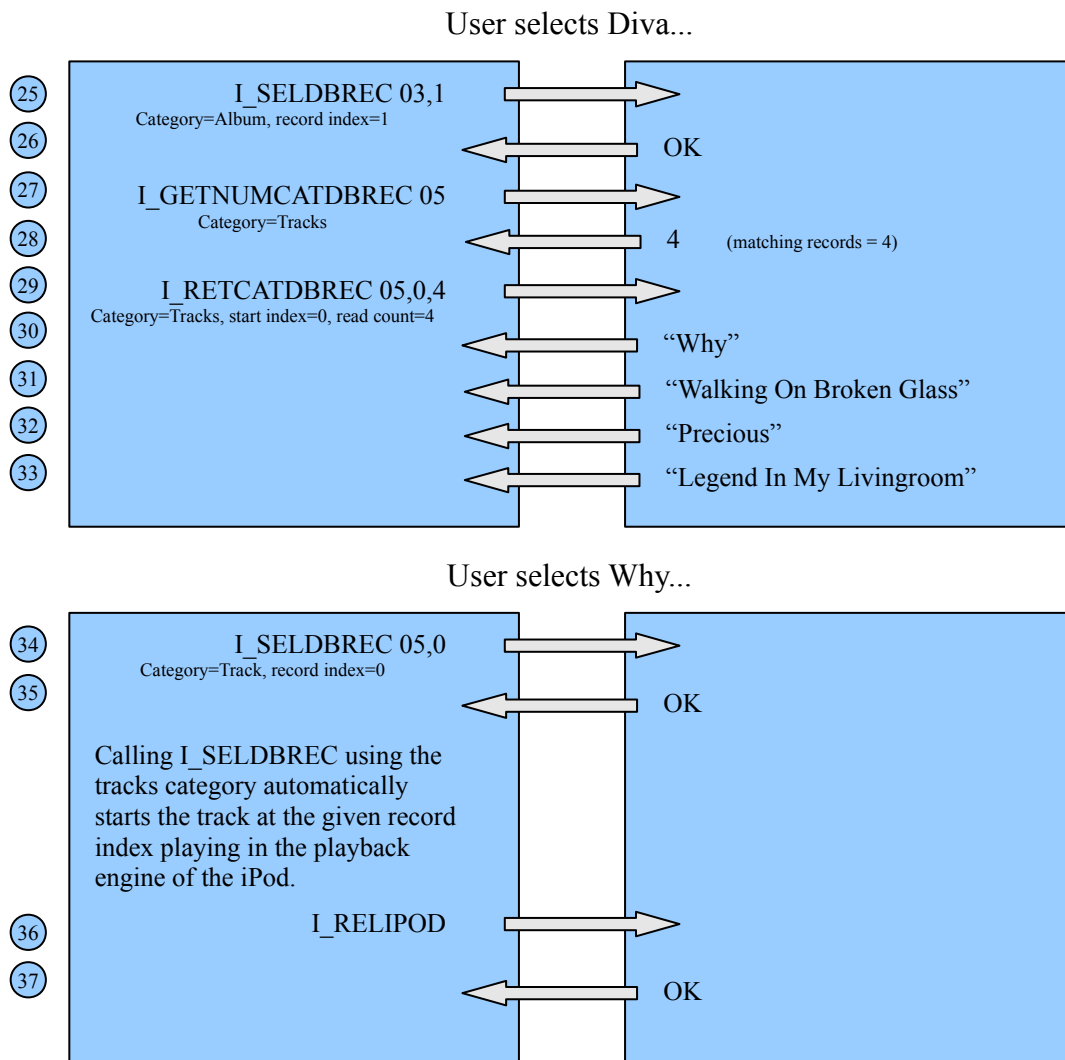

If, at step number 25 the command I_PLYCURSEL 0 was used instead, then all of Annie Lennox's albums would have been sent to the iPod's playback engine.